

# GRADE 9+

## Extended Programme

---

**MATHEMATICS**

**Practice Paper 1**  
**1 Hour**

---

**Read these instructions first**

- Write your name in the space provided below.
- Use black or blue ink.
- HB pencils may be used for the diagrams / sketches only.
- Do not use correction fluid.
- Read each question carefully.
- All answers must be written in the spaces provided.
- Answer all questions.
- Any rough working should be done in this booklet.
- Each question carries 1 mark.
- The total number of marks for this paper is 40 marks.

**Name of student :** .....



**ANSWER ALL QUESTIONS**

1. Write in figures **two hundred and thirty five**.

Answer: .....  
\_\_\_\_\_

2. Work out

$$\begin{array}{r} 1023 \\ + 745 \\ \hline \\ \hline \end{array}$$

Answer: .....  
\_\_\_\_\_

3. Arrange the numbers 10, 50, 200, 100, 150 in order starting with the **largest**.

Answer: .....  
\_\_\_\_\_

4. Simplify  $5a + 15a$

Answer: .....  
\_\_\_\_\_

5. What is the order of matrix  $A = \begin{pmatrix} 1 & -2 \\ 0 & 3 \end{pmatrix}$ ?

Answer: .....  
\_\_\_\_\_

6. Convert 2 hours into minutes

Answer: .....  
\_\_\_\_\_

7. Name the polygon shown below.

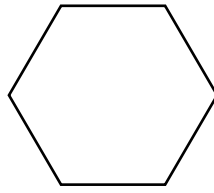

Answer: .....

---

8. Calculate 10 % of Rs 500

Answer: .....

---

9. Evaluate  $3^2$

Answer: .....

---

10. Simplify the ratio 10 : 40

Answer: .....

---

Circle the letter corresponding to the correct answer in each of the following items from questions 11 to 20.

11. 
$$\begin{array}{r} 101 \\ \times 5 \\ \hline \\ \hline \end{array}$$

- A 550
  - B 505
  - C 106
  - D 105
- 

12. What fraction of the diagram is shaded?

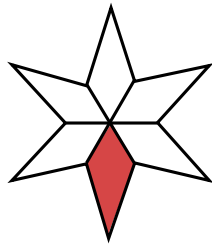

- A  $\frac{5}{6}$
  - B  $\frac{2}{6}$
  - C  $\frac{1}{6}$
  - D  $\frac{1}{12}$
- 

13. Which one of the following is a prime number?

- A 9
  - B 6
  - C 4
  - D 3
- 

14. A multiple of 3 is

- A 9
  - B 10
  - C 11
  - D 14
-

15.  $\sqrt[3]{27}$  is

- A 9
  - B 4
  - C 3
  - D 2
- 

16. 0.247 correct to 2 decimal places is

- A 0.20
  - B 0.24
  - C 0.25
  - D 0.28
- 

17. 42 expressed to the nearest 10 is







- A 40
  - B 50
  - C 55
  - D 60
- 

18. What type of angle is  $55^\circ$ ?

- A reflex
  - B straight
  - C obtuse
  - D acute
- 

19. On which days were the same number of apples sold?

- A Monday and Friday
- B Thursday and Friday
- C Tuesday and Thursday
- D Monday and Wednesday

Day	Number of apples sold
Monday	
Tuesday	
Wednesday	
Thursday	
Friday	
Saturday	
Sunday	

Key:  = 2 apples

---

20. State the mode of the numbers 8, 3, 2, 3, 8, 3

- A 2
- B 3
- C 8
- D 27

---

21. Q is the centre of the circle. QR is called the ..... of the circle.

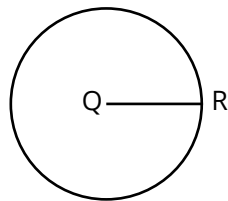

Answer: .....

---

22. Solve the equation  $4x = 12$

Answer: .....

---

23. Factorise  $b^2 - 3b$

Answer: .....

---

24. Evaluate  $\frac{3}{8} + \frac{2}{8}$

Answer: .....

25. Find the value of  $\sqrt{49}$

Answer: .....

---

26. Find the L.C.M. of 12 and 18

Answer: .....

---

27. Six pencils cost Rs 36. What is the cost of 1 pencil?

Answer: .....

---

28. The 17<sup>th</sup> of February was a Sunday. On which day was the 26<sup>th</sup> of February in the same year?

Answer: .....

---

29. From the Venn diagram find  $n(A \cap B)$

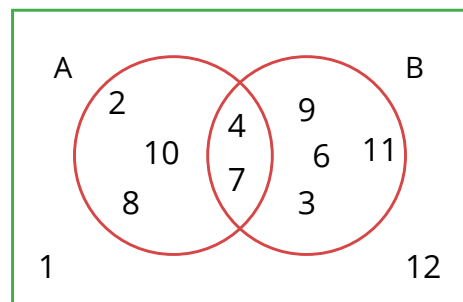

Answer: .....

---



30. Find the unknown angle.

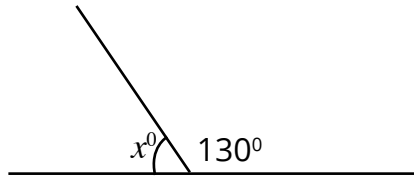

Answer: .....  $x^\circ =$  .....

---

31. Draw the line(s) of symmetry of the given shape.

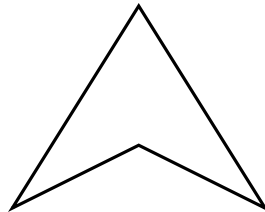

---

32. The temperature in Paris is  $6^\circ\text{C}$  and the temperature in Port Louis is  $24^\circ\text{C}$ .  
What is the difference between the temperatures in Paris and Port Louis?

Answer: .....

---

33. A fair coin is tossed. What is the probability of obtaining a tail?

Answer: .....

---

34. Find the perimeter of the following triangle.

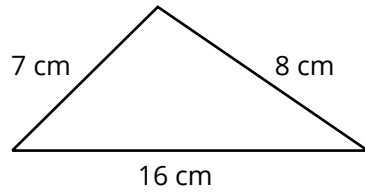

Answer: .....

---

35. What is the name of the following 3-D shape?



Answer: .....

---

36. Find the missing number

$$50 \times \square + 20 = 170$$

Answer: .....

---

37. Find the mean of 8, 12, 11 and 9.

Answer: .....

---

38. The following pie chart shows favourite foods preferred by students in a class.  
Name the food preferred by most students.

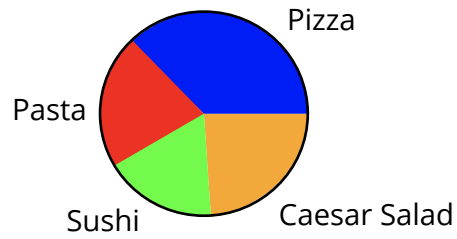

Answer: .....

---

39. Expand  $-3(x - 5)$

Answer: .....

---

40. Plot the coordinates of the point A (2, 4) in the Cartesian plane given below.

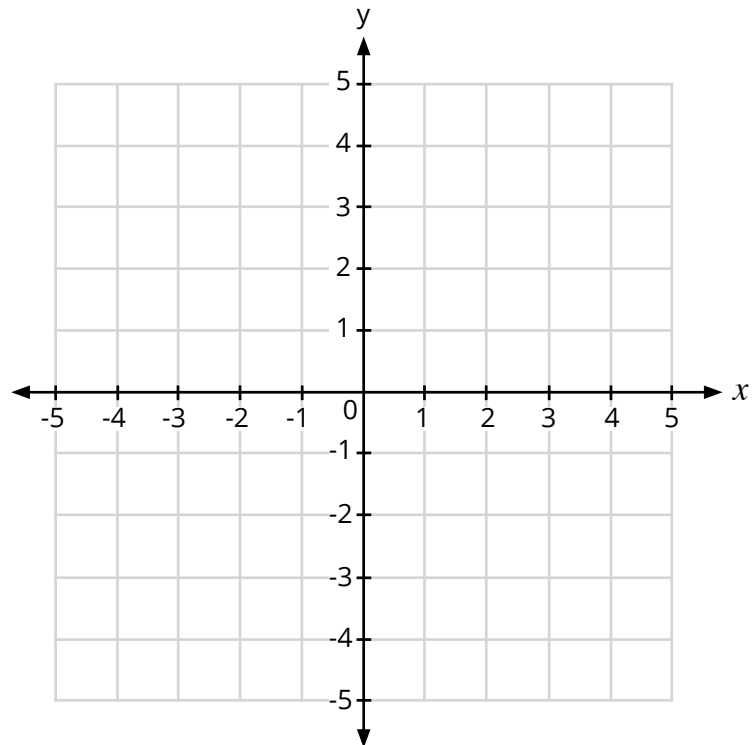

---



# GRADE 9+

## Extended Programme

---

**MATHEMATICS**

**Practice Paper 2**  
**1 Hour**

---

**Read these instructions first**

- Write your name in the space provided below.
- Use black or blue ink.
- HB pencils may be used for the diagrams / sketches only.
- Do not use correction fluid.
- Read each question carefully.
- All answers must be written in the spaces provided.
- Answer all questions.
- Any rough working should be done in this booklet.
- Each question carries 1 mark.
- The total number of marks for this paper is 40 marks.

**Name of student :** .....



**ANSWER ALL QUESTIONS.**

1. Write 123 in words.

Answer: .....

---

2. Work out

$$\begin{array}{r} 1428 \\ - 321 \\ \hline \\ \hline \end{array}$$

Answer: .....

---

3. Evaluate  $\frac{3}{5} \times 45$

Answer: .....

---

4. Arrange the numbers 15, 20, 5, 10, 25 in **ascending order**.

Answer: .....

---

5. Find the value of  $7 + (2 \times 3)$

Answer: .....

---

6. Shade  $\frac{3}{8}$  of the given diagram.

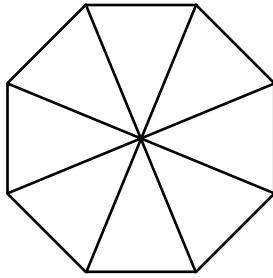

---

7. Simplify  $3a + 7a - 8a$

Answer: .....

---

8. Simplify  $x^5 \times x^7$

Answer: .....

---

9. Expand the following  $-4(x - 3)$

Answer: .....

---



10. Solve the following equation:

$$x + 7 = -3$$

Answer: .....

---

**Circle the letter corresponding to the correct answer in each of the following items from questions 11 to 20.**

11.  $66 \div 6 =$

- A 392
  - B 72
  - C 60
  - D 11
- 

12. Express 0.017 as a fraction.

- A  $\frac{17}{10}$
  - B  $\frac{17}{100}$
  - C  $\frac{17}{1000}$
  - D  $\frac{17}{10000}$
- 

13.  $\frac{3}{4}$  m = ..... cm

- A 7.5
  - B 25
  - C 50
  - D 75
- 

14. The value of angle  $x$  is .....

- A  $15^\circ$
- B  $25^\circ$
- C  $105^\circ$
- D  $35^\circ$

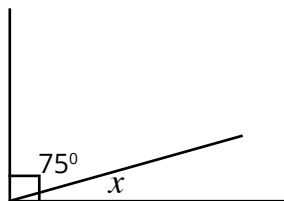

15. The factors of 4 are .....

- A 1, 2
  - B 1, 2, 4
  - C 1, 4, 8
  - D 1, 2, 4, 8
- 

16. Which one of the following polygons is a parallelogram?

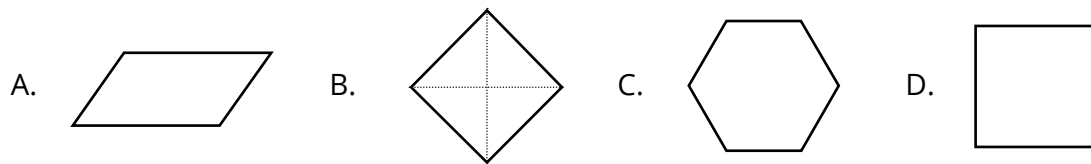

17. The elements of  $M \cap N$  are \_\_\_\_\_

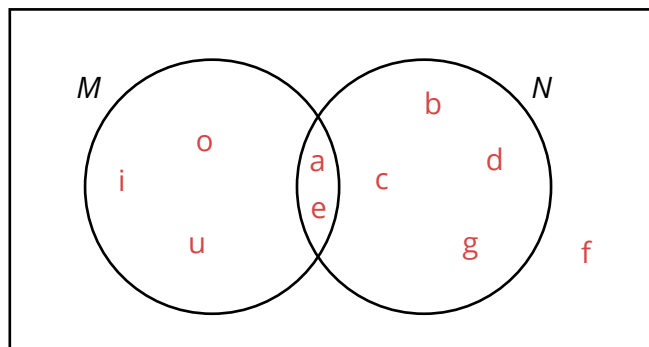

- A { a, b, c, d, e, g, i, o, u }
  - B { b, c, d, f, g, o, i, u }
  - C { a, e }
  - D { f }
- 

18. The regular polygon below has ..... lines of symmetry.



19. In the following diagram, O is the centre of the circle. Line AB is called the ..... of the circle.

- A circumference
- B diameter
- C radius
- D chord

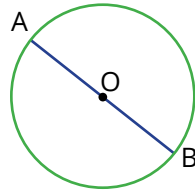

20. The time shown in the clock below is .....

- A quarter to five
- B five o'clock
- C quarter past five
- D half past five

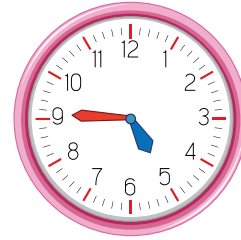

21. Factorise completely  $3y^2 - 15y$

Answer: .....

---

22. Complete the given Fibonacci sequence

1, 4, 5, 9, .....

Answer: .....

---

23. Find the H.C.F. of 24 and 36.

Answer: .....

---

24. A bus leaves Port Louis at 13 40 and reaches Mahebourg and 14 55. Calculate the time taken for this journey in hour and minutes.



Answer: .....

---

25. A basket contains 30 apples. 6 apples are rotten. Find the percentage of rotten apples in the basket.



Answer: .....

---

26. Given  $\begin{pmatrix} 2 \\ 3 \end{pmatrix} + \begin{pmatrix} 3 \\ x \end{pmatrix} = \begin{pmatrix} 5 \\ 4 \end{pmatrix}$ , find the value of  $x$ .

Answer: .....

---

27. Find the area of the following rectangle.



Answer: .....

---

28. Evaluate 25% of 1000 kg.

Answer: .....

---

29. The average daily temperature for a particular week at Bagatelle is shown in the table below.

Monday	Tuesday	Wednesday	Thursday	Friday
18 °C	16 °C	14 °C	21 °C	13 °C

Which day had the coldest temperature?

Answer: .....

---

30. A bag contains 5 red marbles and 6 blue marbles. One marble is taken from the bag at random. What is the probability that it will be a blue marble?

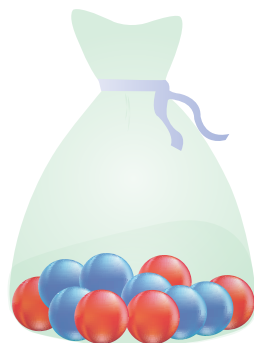

Answer: .....

---

31. Write down the equation of the line given in the Cartesian plane below.

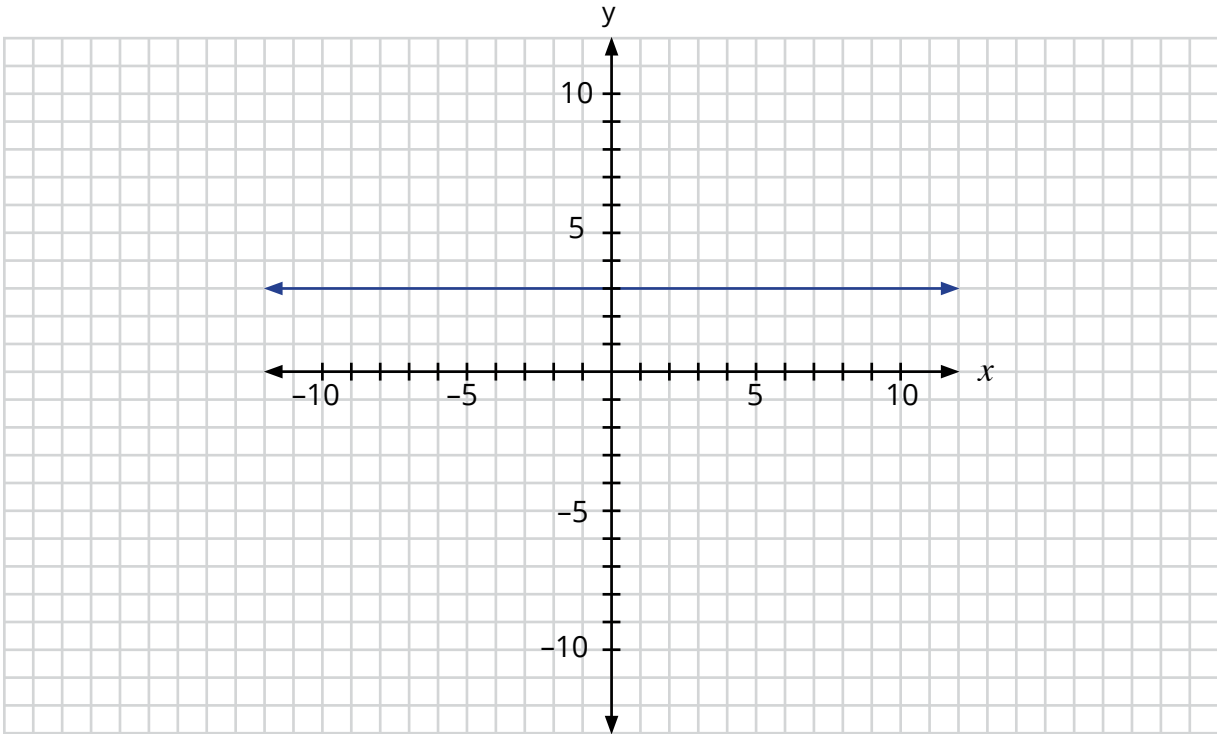

Answer: .....

---

32. The following diagram shows a cube of side 3 cm. Find the volume of the cube.

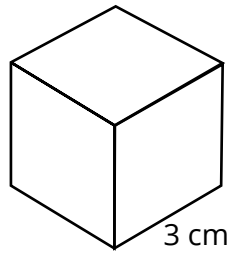

Answer: .....

---

33. State the mode of the following numbers 5, 1, 9, 4, 9, 2, 9.

Answer: .....

---

34. Find the total number of children who like cats and rabbits.

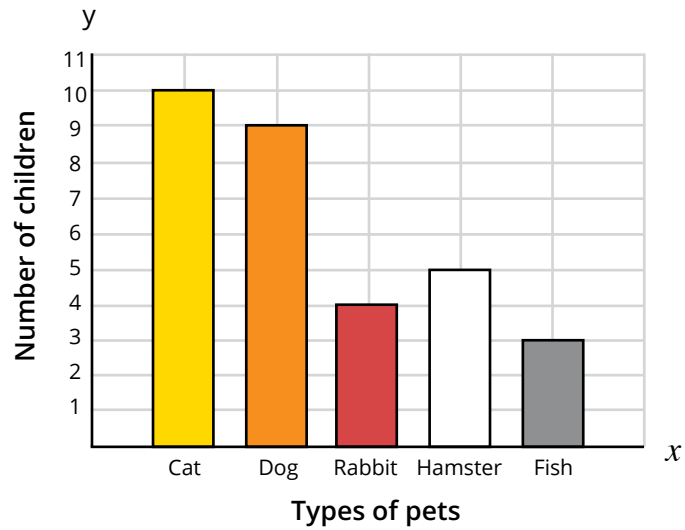

Answer: .....

---

35. A vegetable seller bought 50 kg of potatoes for Rs 600.  
He sold all the potatoes for Rs 850. Find the profit which he made.

Answer: .....

---

36. A car travels 80 km in 2 hours. Calculate its speed in km/h.

Answer: .....

---

37. Find the equation of the line having a gradient of 2 and y-intercept -3.

Answer: .....

---

38. A cake costs Rs 5.50. What is the cost of 4 such cakes?



Answer: .....

---

39. Label the given triangle using the following words: hypotenuse, opposite, and adjacent.

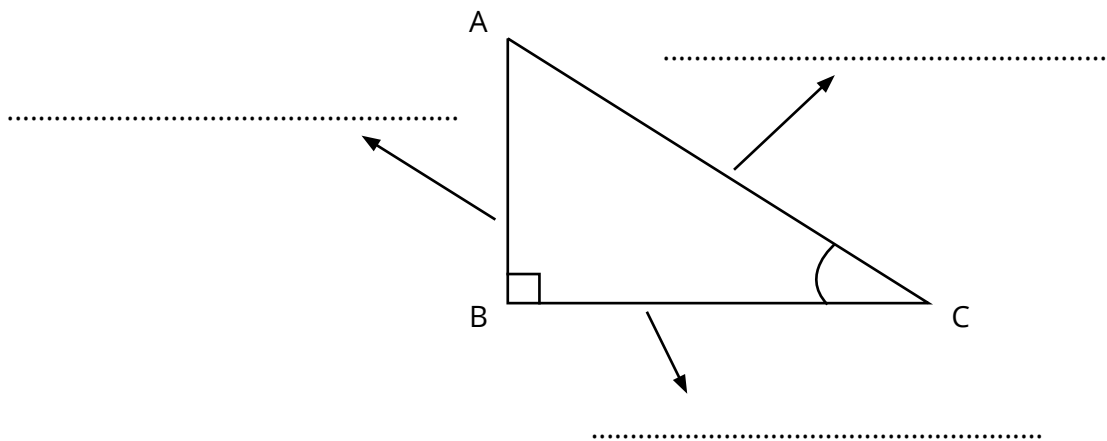

---

40. Find the perimeter of the given square.

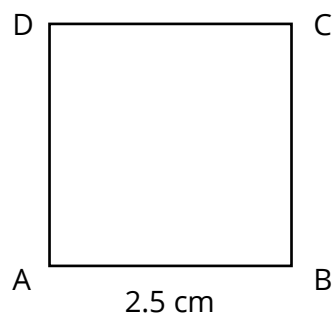

Answer: .....

---



# GRADE 9+

## Extended Programme

---

**MATHEMATICS**

**Practice Paper 3**  
**1 Hour**

---

**Read these instructions first**

- Write your name in the space provided below.
- Use black or blue ink.
- HB pencils may be used for the diagrams / sketches only.
- Do not use correction fluid.
- Read each question carefully.
- All answers must be written in the spaces provided.
- Answer all questions.
- Any rough working should be done in this booklet.
- Each question carries 1 mark.
- The total number of marks for this paper is 40 marks.

**Name of student :** .....



**ANSWER ALL QUESTIONS**

1. Work out 
$$\begin{array}{r} 1045 \\ + 321 \\ \hline \\ \hline \end{array}$$

Answer: .....

---

2. Simplify  $3a + 7a - 2a$

Answer: .....

---

3. Fill in the blank with the symbol  $\subset$  or  $\not\subset$ .

$\{8\}$  .....  $\{1, 3, 5, 8\}$

---

4. What is the name of the following figure?

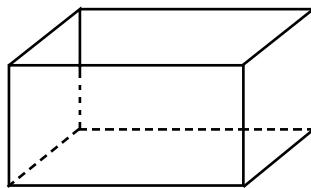

Answer: .....

---

5. Simplify  $(p^3)^2$

Answer: .....

---

6. Complete the sequence given below

10, 7, 4, 1, .....

---

7. Draw the minute and hour hand in the following clock face to show quarter to six.

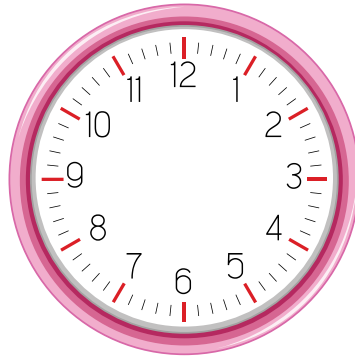

8. Convert the following

580 mm = ..... cm

---

9. Evaluate  $\frac{4}{5} \div \frac{4}{10}$

Answer: .....

---

10. Express  $\frac{3}{25}$  as a decimal.

Answer: .....

---

**Circle the letter corresponding to the correct answer in each of the following items from questions 11 to 20.**

11. Two hundred and fifty one written in figures is

- A 251
  - B 215
  - C 152
  - D 521
- 

12. How many line(s) of symmetry does the following figure have?

- A 0
- B 1
- C 2
- D 4



13. The diameter of a circle with radius 14 cm is

- A 88 cm
  - B 28 cm
  - C 14 cm
  - D 7 cm
- 

14. 0.70 as a fraction is

- A  $\frac{7}{10}$
  - B  $\frac{7}{100}$
  - C  $\frac{7}{1000}$
  - D  $\frac{1}{7}$
- 

15. The ratio 3 : 15 in its simplest form is

- A 5 : 3
  - B 5 : 1
  - C 3 : 5
  - D 1 : 5
-

16. The value of angle  $e$  is

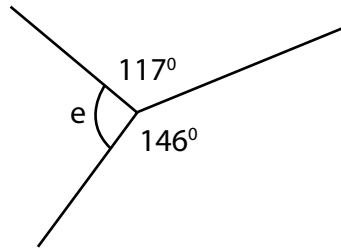

- A  $34^\circ$
  - B  $63^\circ$
  - C  $97^\circ$
  - D  $263^\circ$
- 

17. The value of  $\sqrt[3]{8}$  is

- A 2
  - B 4
  - C 8
  - D 16
- 

18. The diagram below represents

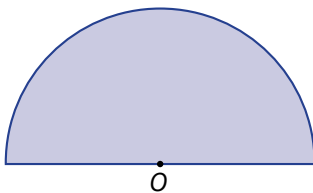

- A a quarter of a circle
  - B a semicircle
  - C three quarter of a circle
  - D a complete circle
- 

19. In the following diagram, the side AC is known as the

- A opposite
- B adjacent
- C diameter
- D hypotenuse

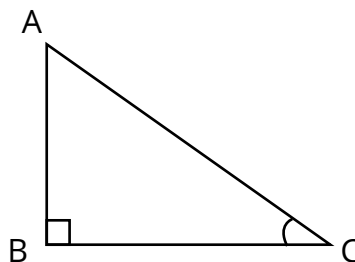

20. A car covers a total distance of 90 km at an average speed of 60 km/h. The time taken to travel this distance is ..... minutes.

- A 30
  - B 90
  - C 120
  - D 150
- 

21. Solve the inequality  $x - 1 < 7$

Answer: .....

---

22. Factorise completely  $3v - 9v^2$

Answer: .....

---

23. Yash has 36 marbles. She gives  $\frac{1}{3}$  of them to her sister Komal. How many marbles does Yash have left?

Answer: .....

---

24. Solve the following equation

$$3x = -12$$

Answer: .....

---

25.  $O$  is the centre of the given circle below. Draw one diameter of the circle.

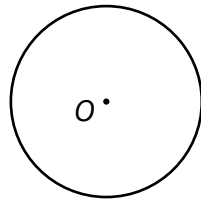

---

26. Find the L.C.M. of 5, 10 and 15

Answer: .....

---

27. Complete the following factor tree.

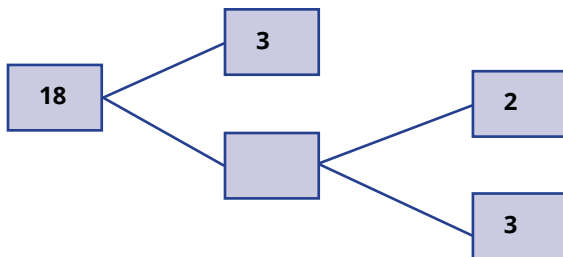

---

28. Find the perimeter of the rectangle below.

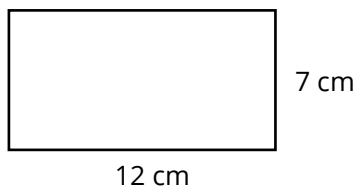





Answer: .....

---



29. The following pictogram shows the fruit preferred by the children in a class. Find the total number of children in the class.

Key: 😊 means 1 child

Fruit	Favourite Fruit
 apple	😊😊😊😊😊
 banana	😊😊😊😊😊😊😊
 strawberry	😊😊😊
 pear	😊😊
 orange	😊😊😊😊

Answer: .....

---

30. List the elements of the set  $D \cup M$ .

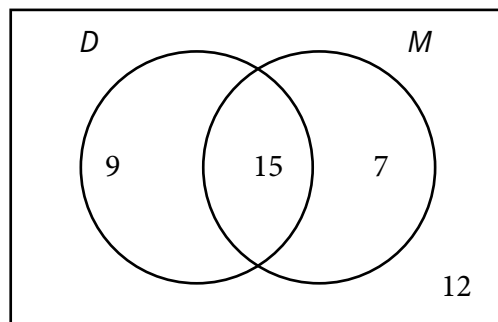

Answer: .....

---

31. Find the ratio of the number of apples to the number of oranges in its simplest form.



apples



oranges

Answer: .....

---

32. Draw the line  $x = 4$  in the Cartesian plane given below.

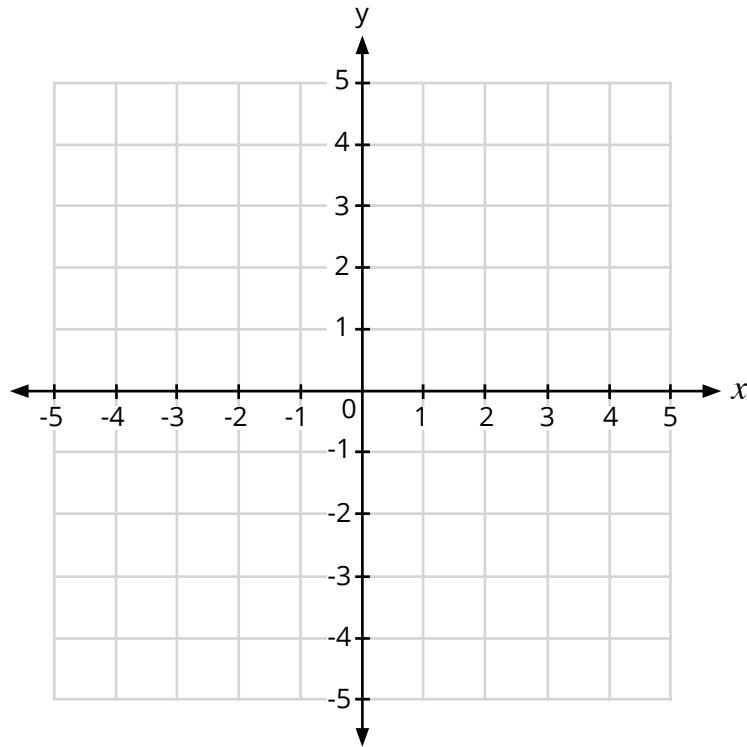

---

33. A taxi leaves Rose Hill at 14 25 and reaches SSR airport 55 minutes later. At what time does the taxi reach the airport?

Answer: .....

---

34. Arav had Rs 100. He bought 2 sketch pads for Rs 76. How much money did he have left?

Answer: .....

---

35. Given  $X = \begin{pmatrix} 1 & 2 \\ -1 & -3 \end{pmatrix}$  and  $Y = \begin{pmatrix} 1 & 0 \\ 4 & 3 \end{pmatrix}$ .

Find  $X + Y$ .

Answer: .....

---

36. The spinner below is rotated once. Find the probability that the arrow will point to the number 1.



Answer: .....

---

37. The height of the cylinder 12 cm.

If it is **three quarter** full, find the depth of water in the cylinder.

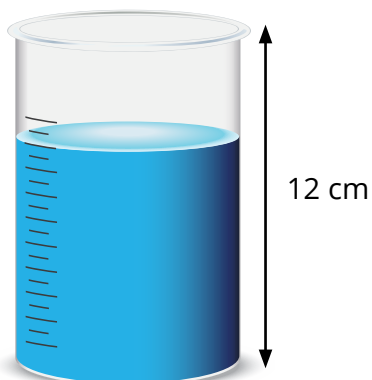

Answer: .....

---

38. Vinaye pays a shirt for Rs 650 after getting a discount of Rs 125. Find the normal price of the shirt.

Answer: .....

---

39. Find the volume of the given cuboid.

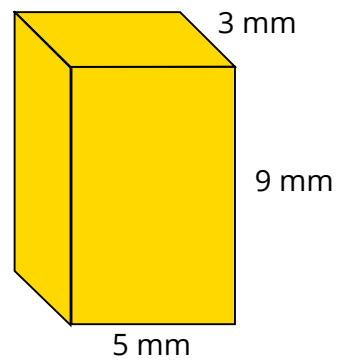

Answer: .....

---

40. The length of a running track is 400 m. Usain runs 5 times along the track. What distance does he cover in kilometres?



Answer: .....

---

# GRADE 9+

## Extended Programme

---

**MATHEMATICS**

**Practice Paper 4**  
**1 Hour**

---

**Read these instructions first**

- Write your name in the space provided below.
- Use black or blue ink.
- HB pencils may be used for the diagrams / sketches only.
- Do not use correction fluid.
- Read each question carefully.
- All answers must be written in the spaces provided.
- Answer all questions.
- Any rough working should be done in this booklet.
- Each question carries 1 mark.
- The total number of marks for this paper is 40 marks.

**Name of student :** .....



1. Work out

$$\begin{array}{r} 257 \\ - 132 \\ \hline \\ \hline \end{array}$$

Answer: .....

---

2. Shade  $\frac{1}{5}$  of the diagram

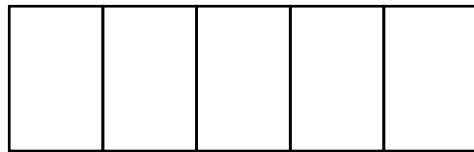

---

3. Circle the even number.

33 , 34 , 67 , 65

---

4. Evaluate  $\frac{5}{7} - \frac{2}{7}$

Answer: .....

---

5. An octagon has ..... sides.

---

6. Convert 2 *m* into *cm*.

Answer: .....

---

7. Complete the pattern

(1, 1), (1, 2), (1, 3), ( ..... , ..... )

---

8. Shade  $A \cup B$

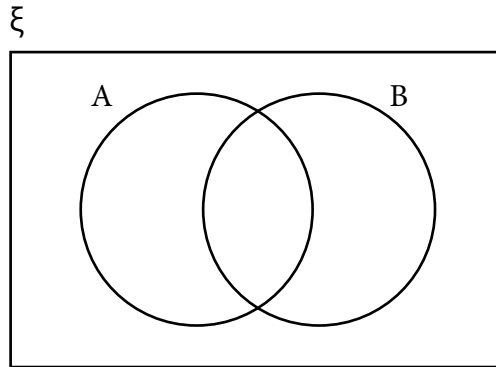

9. Find the mean of 15, 10 and 11.

Answer: .....

---

10. Calculate 10% of 250

Answer: .....

---

**Circle the letter corresponding to the correct answer in each of the following items from questions 11 to 20.**

11. What is the value of  $\frac{1}{3} \times 9$ ?

- A    1
  - B    2
  - C    3
  - D    9
-



12.  $\frac{3}{100} = \dots\dots\dots$

- A 0.3
  - B 0.03
  - C 0.003
  - D 300
- 

13. The gradient of the line  $y = 2x + 3$  is  $\dots\dots\dots$

- A 0
  - B 1
  - C 2
  - D 3
- 

14.  $2 \times 2 \times 2 \times 2 \times 2$  is equal to  $\dots\dots\dots$

- A  $2^2$
  - B  $2^3$
  - C  $2^4$
  - D  $2^5$
- 

15. The solid shape shown below is a  $\dots\dots\dots$

- A cone
- B cylinder
- C sphere
- D cube

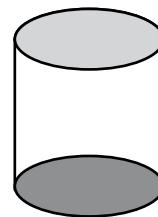

16. The area of a circle having radius  $r$  units is  $\dots\dots\dots$

- A  $\pi r^2$
  - B  $2\pi r^2$
  - C  $2\pi r$
  - D  $4\pi r^2$
-

17. How many vertices are there in the figure below?

- A 5
- B 3
- C 2
- D 4

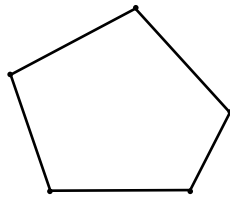

---

18. Which of the following is a binomial expression?

- A  $3x$
- B  $4p + 5$
- C  $2x + 3y - 5$
- D  $4a - 7ab + 3b + 1$

---

19. The perimeter of the figure is

- A 2 m
- B 4 m
- C 8 m
- D 16 m

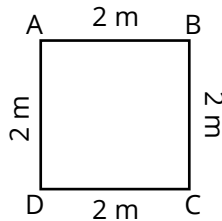

---

20. How many line(s) of symmetry are there in the given figure?

- A 1
- B 2
- C 3
- D 4

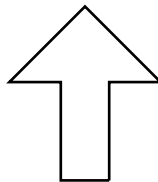

---

21. Complete

$24 \div 6 - \square = 3$

Answer: .....

---

22. Write **greater** or **less** in the space below



5 L  
Object A



250 mL  
Object B

Object A has ..... capacity than object B.

---

23. Simplify  $2a + 3a$

Answer: .....

---

24. Fill in the box with  $<$  or  $>$

-12  23

---

25. Factorise  $2x + 10$

Answer: .....

---

26. Complete the pattern below.

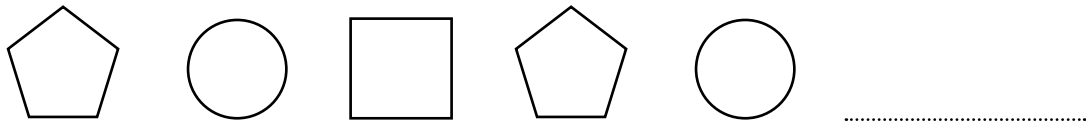

27. Draw the hands of the clock to show **half past four**.

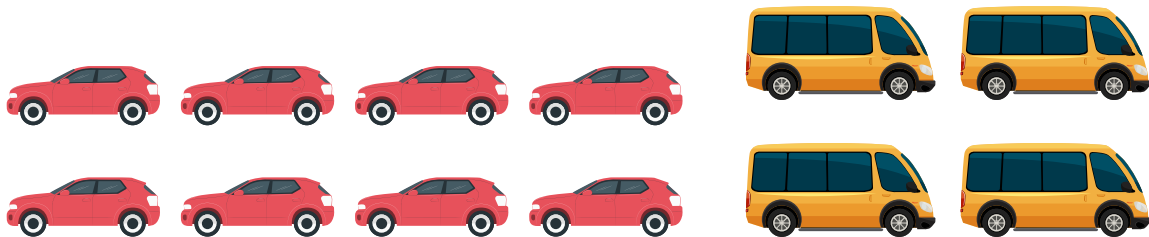
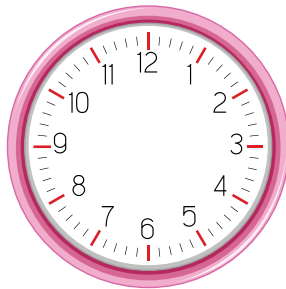

28. The simplest ratio of the number of cars to the number of vans is ..... : .....

29. Match the correct trigonometric ratio

$$\cos \theta =$$

$\frac{\text{adjacent}}{\text{hypotenuse}}$

$\frac{\text{opposite}}{\text{adjacent}}$

$\frac{\text{opposite}}{\text{hypotenuse}}$

30. Perform the matrix addition

$$\begin{pmatrix} 1 & 2 \\ -1 & -3 \end{pmatrix} + \begin{pmatrix} 1 & 2 \\ -1 & -3 \end{pmatrix} = \begin{pmatrix} & \\ & \end{pmatrix}$$

---

31. A jar contains 5 red and 2 green sweets.

The probability of taking a **red** sweet at random is .....



32. Find the **area** of the rectangular garden having length 10 m and width 7 m.

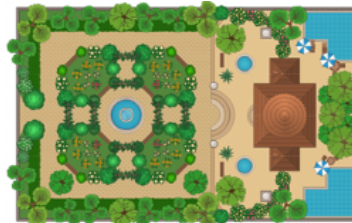

Answer: .....

---

33. Sam bought a pair of shoes in a sale. The price was reduced from Rs 750 to Rs 500. Find the discount.



Answer: .....

---

34. At the market, Mary buys 200 g of apples and 225 g of grapes.  
What is the **total** mass of fruits bought?



200 g



225 g

Answer: .....

---

35. A watch costing Rs 1200 is sold for Rs 1500.  
Calculate the profit.

Answer: .....

---

36. Find angle  $x$  .

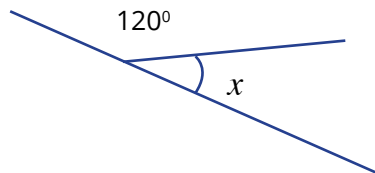

Answer: .....  $x =$  .....

---

37. The cost of a notebook is Rs. 35.  
Find the cost of 4 such notebooks.

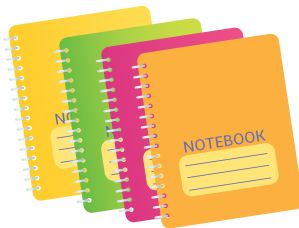

Answer: .....

---

38. The table shows the favourite colour of each student in a class.

Favourite Colour	Number of students
Red	13
Blue	6
Yellow	6
Green	5

Study the table and complete the sentence below.

..... and ..... are the favourite colours for the **same** number of students.

---

39.

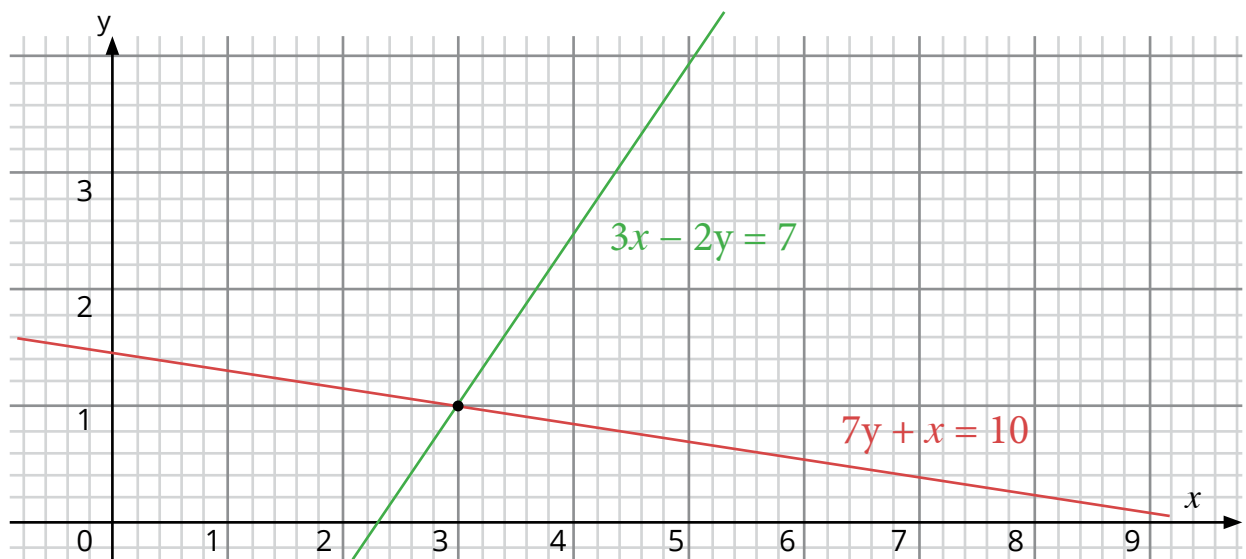

The point of intersection of the two lines in the diagram is ( ....., ..... )

---

40. Find the volume of the cube with each edge of length 6 cm.

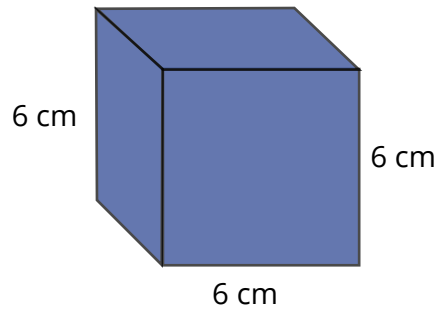

Answer: .....

---



# GRADE 9+

## Extended Programme

---

**MATHEMATICS**

**Practice Paper 5**  
**1 Hour**

---

**Read these instructions first**

- Write your name in the space provided below.
- Use black or blue ink.
- HB pencils may be used for the diagrams / sketches only.
- Do not use correction fluid.
- Read each question carefully.
- All answers must be written in the spaces provided.
- Answer all questions.
- Any rough working should be done in this booklet.
- Each question carries 1 mark.
- The total number of marks for this paper is 40 marks.

**Name of student :** .....



1. Work out

$$\begin{array}{r} 322 \\ + 573 \\ \hline \\ \hline \end{array}$$

Answer: .....

---

2. Express 0.37 as a fraction.

Answer: .....

---

3. Calculate  $4.2 \times 2$

Answer: .....

---

4. Simplify 10 : 15

Answer: .....

---

5. Convert 5 hours into minutes.

Answer: .....

---

6. Simplify  $7p - 5p$ .

Answer: .....

---

7. Find the value of  $\sqrt{81}$

Answer: .....

---

8. Simplify  $x^3 \times x^6$

Answer: .....

---

9. Kevin bought a cake. He eats  $\frac{1}{4}$  of it. What fraction of the cake is left?

Answer: .....

---

10. Find the H.C.F. of 14 and 42.

Answer: .....

---

**Circle the letter corresponding to the correct answer in each of the following items from questions 11 to 20.**

11. A decimal number between 2.1 and 2.3 is .....

- A 2.0
  - B 2.1
  - C 2.2
  - D 2.3
-

12. What fraction of the diagram is shaded?

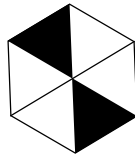

A  $\frac{1}{2}$

B  $\frac{1}{3}$

C  $\frac{1}{4}$

D  $\frac{1}{5}$

---

13. The figure below has ..... of symmetry.

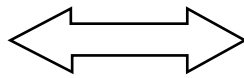

A no line

B 1 line

C 2 lines

D 4 lines

---

14. The angle  $200^\circ$  is ..... angle.

A an acute

B an obtuse

C a right

D a reflex

---

15. A pentagon has ..... sides.

A 4

B 5

C 6

D 7

---

16. Which of the following is a regular polygon?

A Square

B Scalene triangle

C Rectangle

D Isosceles triangle

---

17. Which of the following coordinates lie on the line with equation  $y = x + 3$  ?

- A (2, 4)
  - B (2, 5)
  - C (2, 6)
  - D (2, 7)
- 

18. Wayne makes a loss of Rs 200 when he sells a calculator for Rs 800.  
Find the buying price of the calculator.

- A Rs 400
  - B Rs 600
  - C Rs 1000
  - D Rs 1600
- 

19. Dhyana pays a bill of Rs 172 with a 200-rupee note. The change that she receives is

.....

- A Rs 28
  - B Rs 38
  - C Rs 128
  - D Rs 372
- 

20.

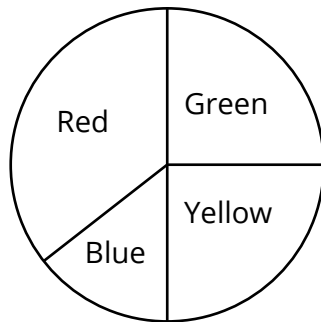

The above diagram is known as a

- A bar chart
  - B Venn diagram
  - C pictogram
  - D pie chart
-

21. Write down the next term in the sequence below

3, 8, 13, .....

---

22. Arrange the following numbers in **ascending order**.

3.7, 3.2, 7.2, 2.7

Answer: .....

---

23. Convert 4.2 kilometres into metres.

Answer: .....

---

24. ABC is a right-angled triangle. AC is called the .....

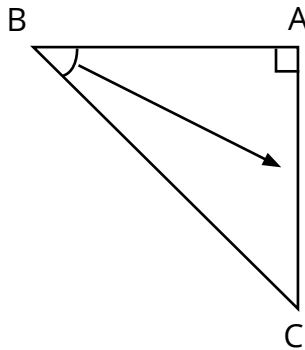

---

25. What is the smallest integer value of  $y$  given that  $y > 7.2$ ?

Answer: .....

---

26. Calculate the area of the rectangle given below.

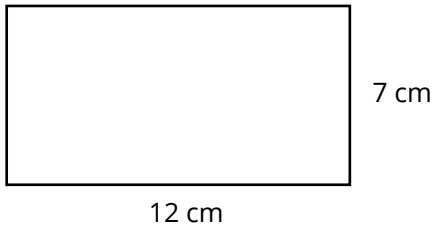

Answer: .....

---

27. Which box is heavier?

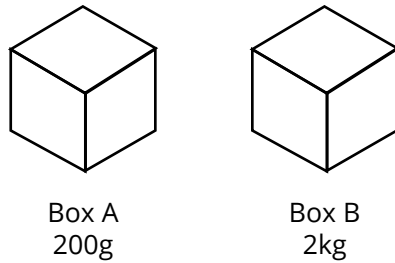

Answer: .....

---

28. The radius of a circle is 4.5 cm. Find its diameter.

Answer: .....

---

29. State the gradient of the line with equation  $y = -5x + 6$ .

Answer: .....

---



30. Solve the equation

$$x - 5 = 2$$

Answer: .....

---

31. Given that  $m = -5$ , find the value of the expression  $2m - 3$ .

Answer: .....

---

32. It is given that  $p + 2q = r$ . Make  $p$  the subject of the formula.

Answer: .....

---

33. Work out

$$\begin{pmatrix} 5 \\ 2 \end{pmatrix} + \begin{pmatrix} 4 \\ -1 \end{pmatrix}$$

Answer: .....

---

34. It is given that  $\vec{AB} = \begin{pmatrix} 5 \\ 1 \end{pmatrix}$ . Write down the vector  $\vec{BA}$ .

Answer: .....

---

35. Calculate the value of angle  $x$  in the diagram below.

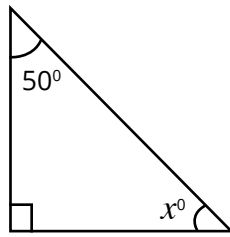

Answer: .....

---

36. It is given that  $A = \{1, 2, 3, 4\}$  and  $B = \{3, 4, 5, 6\}$ .

List the elements of the set  $A \cap B$ .

Answer: .....

---

37. Find the **mean** of the numbers 2, 5, 6, 4, 3.

Answer: .....

---

38. Given that  $A = \begin{pmatrix} 1 & -3 \\ 0 & -2 \end{pmatrix}$ , find  $3A$ .

Answer: .....

---

39. Nat has 5 sweets of which 2 are red and 3 are yellow. She selects a sweet at random. What is the probability that she selects a yellow sweet?

Answer: .....

---

40. Calculate the volume of the cuboid given below.

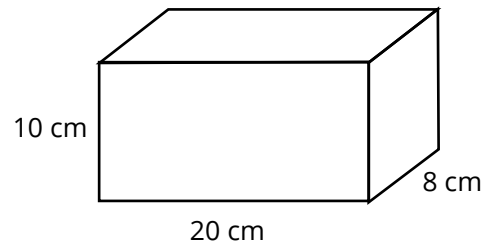

Answer: .....

---



# GRADE 9+

## Extended Programme

---

**MATHEMATICS**

**Practice Paper 6**  
**1 Hour**

---

**Read these instructions first**

- Write your name in the space provided below.
- Use black or blue ink.
- HB pencils may be used for the diagrams / sketches only.
- Do not use correction fluid.
- Read each question carefully.
- All answers must be written in the spaces provided.
- Answer all questions.
- Any rough working should be done in this booklet.
- Each question carries 1 mark.
- The total number of marks for this paper is 40 marks.

**Name of student :** .....



1. Work out.

$$\begin{array}{r} 351 \\ - 120 \\ \hline \\ \hline \end{array}$$

Answer: .....

---

2. What fraction of the figure is shaded?

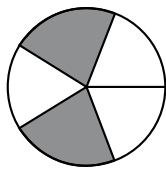

Answer: .....

---

3. Ring the square number.

2.1   4    $8\frac{1}{3}$    27

---

4. Evaluate  $2 \times 3 - 1$

Answer: .....

---

5. Complete.

2 kg = ..... g

---

6. Evaluate  $5^0$

Answer: .....

---

7. Complete the sequence below.

10, 15, 20, 25, .....

---

8. Simplify  $x + 4x$

Answer: .....

---

9. Consider the set  $A = \{ b, a, s, k, e, t \}$

$n(A) = \dots$

---

10. A heptagon has ..... sides.

---

**Circle the letter corresponding to the correct answer in each of the following items from questions 11 to 20.**

11. How many line(s) of symmetry are there in an isosceles triangle?

- A    1
- B    2
- C    3
- D    4

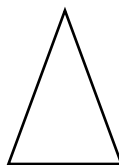



12. The name of the solid shape is a .....

- A sphere
- B cylinder
- C cone
- D cuboid

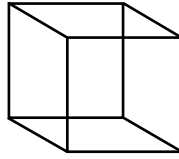

---

13. The coefficient in the term  $5xy$  is .....

- A 1
- B 3
- C 5
- D 10

---

14. What is three tenths as a fraction?

- A  $\frac{3}{10}$
- B  $\frac{3}{100}$
- C  $\frac{3}{1000}$
- D 30

---

15. If  $2x + 3 = 5$ , the value of  $x$  is .....

- A 1
- B 2
- C 5
- D 7

---

16. The mean of the numbers 10, 20, 30 and 40 is

- A 20
  - B 25
  - C 30
  - D 50
-

17. The ratio 4 : 20 in its simplest form is .....

- A 1 : 4
  - B 1 : 5
  - C 4 : 1
  - D 2 : 10
- 

18. Which of the following is an improper fraction?

- A  $\frac{2}{3}$
  - B 0.33
  - C  $\frac{5}{2}$
  - D half
- 

19. The perimeter of the figure is .....

- A 6 cm
- B 7 cm
- C 12 cm
- D 24 cm

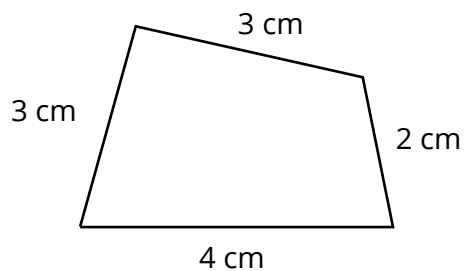

20. The longest side of a right-angled triangle is called its .....

- A opposite
- B adjacent
- C perimeter
- D hypotenuse

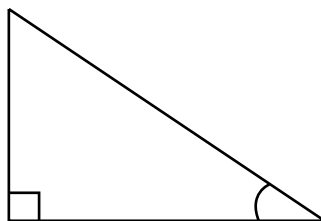

21. The time shown in the clock is .....



Answer: .....

---

22. Write  $-2$  on the number line below.

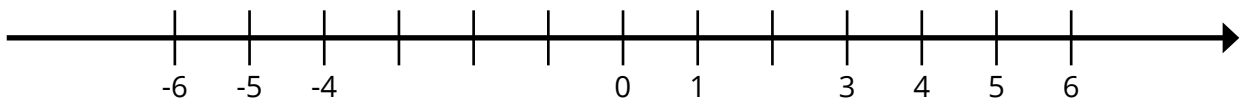

---

23. Calculate 12 % of 200.

Answer: .....

---

24. Find angle  $x$ .

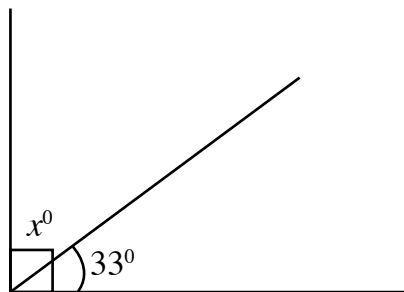

Answer: .....  $x^{\circ} =$  .....

---

25. Fill in with < or >

$$1586 \quad \square \quad 1568$$

---

26. Arrange 5.2, 2.3, 3.4 and 1.7 in **ascending** order.

Answer: .....

---

27. The diameter of a circle with centre O is 20 cm. Find its radius.

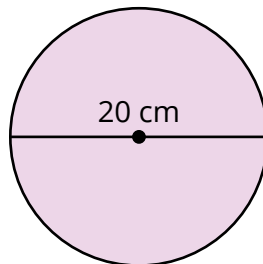

Answer: .....

---

28. Work out.

$$2 \begin{pmatrix} 1 & -5 \\ 3 & 2 \end{pmatrix}$$

Answer: .....

---



32. Find the area of a square of length 5 cm.

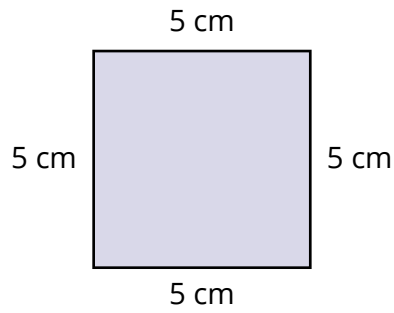

Answer: .....

---

33. Sam has Rs 250. He buys a book for Rs 120.  
How much money has he left?

Answer: .....

---

34. A die is tossed. What is the probability of obtaining a six?



Answer: .....

---

35. Naomi mixes 1 L of water with 50 mL of orange juice. What is the amount of the mixture she gets altogether in mL?



Answer: .....

---

36. After selling a T-shirt for Rs 350, a profit of Rs 125 was made.  
What was the cost price of the T-shirt?

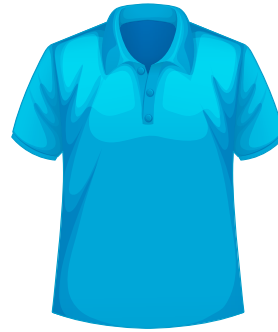

Answer: .....

---

37. Calculate the angle representing 'Children' in the pie chart.

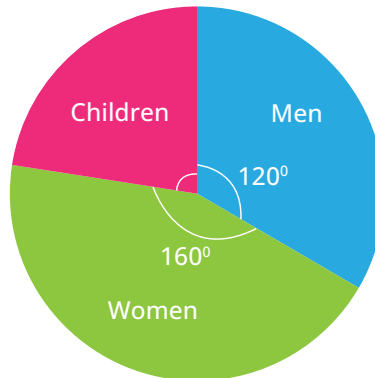

Answer: .....

---

38. Find the volume of water in the tank below.

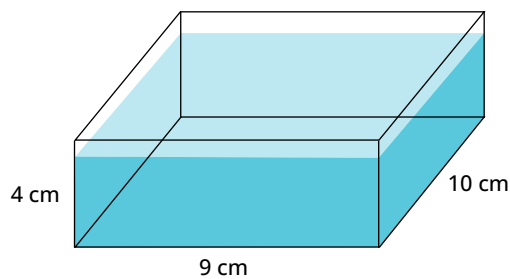

Answer: .....

---

39. A car travels a distance of 40 km in 1 hour.  
What is the distance covered in 3 hours?

Answer: .....

---

40. Draw the line(s) of symmetry of the figure.

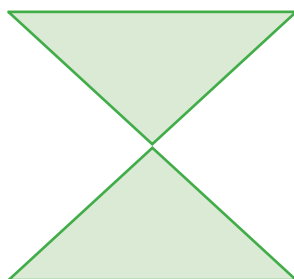

---



# GRADE 9+

## Extended Programme

---

**MATHEMATICS**

**Practice Paper 7**  
**1 Hour**

---

**Read these instructions first**

- Write your name in the space provided below.
- Use black or blue ink.
- HB pencils may be used for the diagrams / sketches only.
- Do not use correction fluid.
- Read each question carefully.
- All answers must be written in the spaces provided.
- Answer all questions.
- Any rough working should be done in this booklet.
- Each question carries 1 mark.
- The total number of marks for this paper is 40 marks.

**Name of student :** .....



1. Work out

$$\begin{array}{r} 302 \\ \times 4 \\ \hline \\ \hline \end{array}$$

---

2. Ring the odd number.

34, 42, 67, 76

---

3. Find the value of  $2^3$

Answer: .....

---

4. Express 23% as a fraction

Answer: .....

---

5. Simplify  $\frac{2}{3} \div 4$

Answer: .....

---

6. Fill in with < or >

2.15  2.45

---

7. Simplify  $8p^2 - 3p^2$

Answer: .....

---

8. Complete the sequence

12, 14, 16, 18, .....

---

9. Make  $x$  the subject of formula in

$$x + b = c$$

Answer: .....

---

10. Write **TRUE** or **FALSE**

12 is exactly divisible by 2. ....

---

Circle the letter corresponding to the correct answer in each of the following items from questions 11 to 20.

11.  $\frac{9}{10} =$

- A 0.9
  - B 0.09
  - C 0.009
  - D 90
- 

12. 40 mm =

- A 400 cm
  - B 4 cm
  - C 0.4 cm
  - D 0.04 cm
- 

13. Which of the following is a quadratic expression?

- A  $x^2 + x + 3$
  - B  $8x - 7$
  - C  $3x^3 - 9$
  - D 5
- 

14. Which one of the following fractions is the **largest**?

- A  $\frac{2}{7}$
  - B  $\frac{3}{7}$
  - C  $\frac{5}{7}$
  - D  $\frac{6}{7}$
-

15. The perimeter of the figure is .....

- A 10 cm
- B 15 cm
- C 20 cm
- D 50 cm

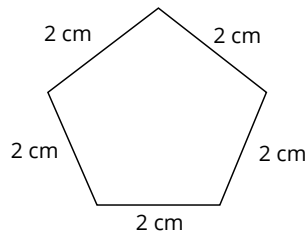

---

16. Between which of the following two whole numbers does 5.3 lie?

- A 2 and 3
- B 3 and 4
- C 4 and 5
- D 5 and 6

---

17. The matrix  $\begin{pmatrix} 0 & 0 \\ 0 & 0 \end{pmatrix}$  is a ..... matrix.

- A row
- B column
- C null
- D identity

---

18. There are 30 boys and 20 girls in a class. The ratio of the number of girls to the number of boys is .....

- A 2 : 3
- B 3 : 2
- C 2 : 5
- D 3 : 5

---

19. The set of points (5, 1), (5, 3) and (5, 5) lie on the line .....

- A  $y = 5$
  - B  $x + y = 5$
  - C  $x = 5$
  - D  $y = x$
-

20. The mode of the set of numbers 2, 3, 3, 3, 4, 5, 5 is \_\_\_\_\_ .

- A 2
- B 3
- C 4
- D 5

---

21. Sam bought one box of sweets for Rs 20. How many boxes can Sam buy if he has Rs 80?

Answer: .....

---

22. Given that  $B = \{s, a, m, e\}$ , fill in the blank with the symbol  $\in$  or  $\notin$ .

m ..... B

---

23. A number is selected at random from the list below:

2, 5, 10, 24, 50.

Find the probability that the number is a multiple of 10.

Answer: .....

---

24. Find angle C.

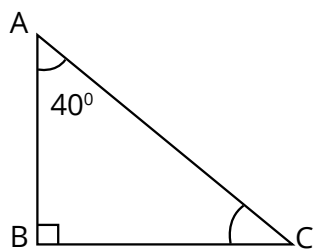

Answer: .....

---

25. Given

$$12 = 2 \times 2 \times 3$$

$$15 = \quad \quad 3 \times 5$$

Find the L.C.M of 12 and 15.

Answer: .....

---

26. Find the mean of 2 kg, 3 kg, 8 kg, 10 kg and 12 kg.

Answer: .....

---

27. Evaluate  $(8)^{\frac{1}{3}}$

Answer: .....

---

28. Work out.

$$\begin{pmatrix} 4 \\ 3 \end{pmatrix} - \begin{pmatrix} 1 \\ 5 \end{pmatrix}$$

Answer: .....

---

29. Kevin travels a distance of 126 km in 3 hours.

Find his average speed in kilometres per hour.

Answer: .....

---



30. A film started at 8.10 p.m and ended at 9.30 p.m.  
What was the duration of the film?

Answer: .....

---

31. Find the value of  $\sin x$ .

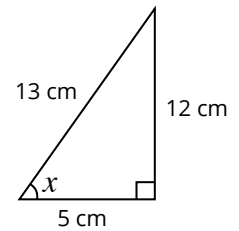

Answer: .....

---

32. Find the area of a rectangle with length 12 cm and width 4 cm.

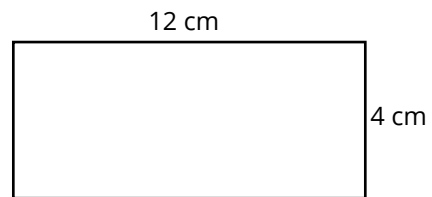

Answer: .....

---

33. Reflect the diagram in the given mirror line.

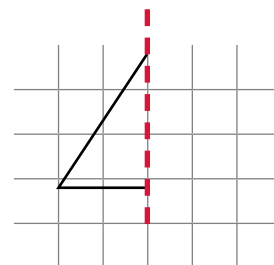

34. A shopkeeper buys a box of chocolates at Rs 200. He later sells it at Rs 150.  
Calculate his loss.



Answer: .....



---

35. In a basket containing 40 apples,  $\frac{3}{8}$  are red. Find the number of red apples in the basket.

Answer: .....

---

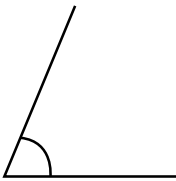
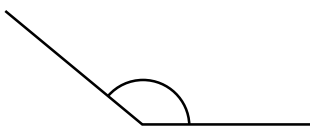
36. Match the following.

Obtuse angle	
Right angle	
Acute angle	

37. The height of the cylinder is 20 cm.  
If its base area is  $35 \text{ cm}^2$ , find its volume.

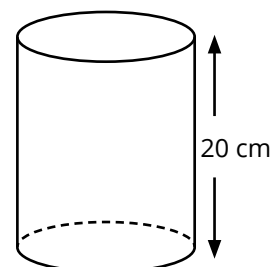

Answer: .....

---

38. Complete with the correct expressions.

Base of triangle = .....  
 Height of triangle = .....  
 Area of the triangle = .....  
 (Do not simplify your answer)

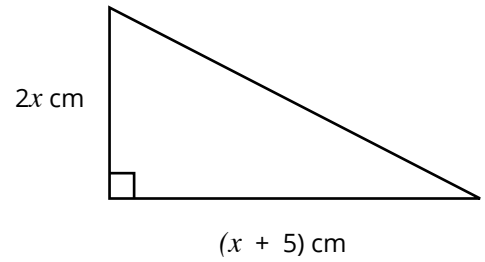

39. Draw pattern 4 in the following :

Pattern 1



Pattern 2

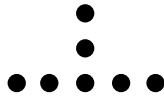

Pattern 3

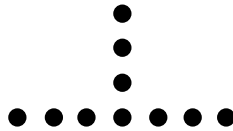

Pattern 4

40. The bar chart shows the number of fruits sold in a week.

Number of fruits

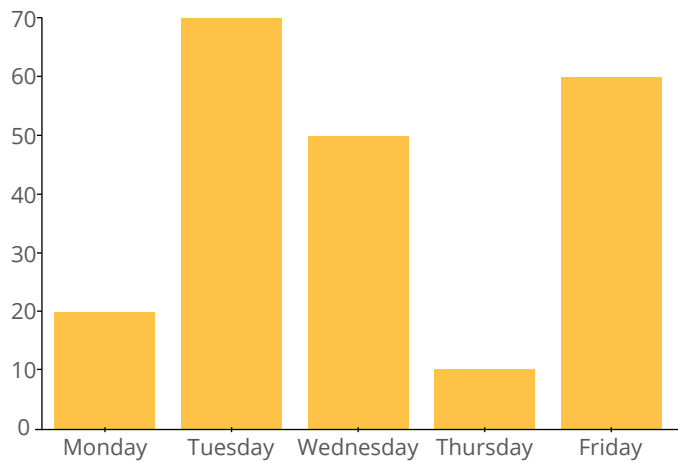

How many **more** fruits were sold on Tuesday than on Thursday?

Answer: .....



# GRADE 9+

## Extended Programme

---

**MATHEMATICS**

**Practice Paper 8**  
**1 Hour**

---

**Read these instructions first**

- Write your name in the space provided below.
- Use black or blue ink.
- HB pencils may be used for the diagrams / sketches only.
- Do not use correction fluid.
- Read each question carefully.
- All answers must be written in the spaces provided.
- Answer all questions.
- Any rough working should be done in this booklet.
- Each question carries 1 mark.
- The total number of marks for this paper is 40 marks.

**Name of student :** .....



1. Work out  $4.9 - 1.7$

Answer: .....  
\_\_\_\_\_

2. Write  $8 \times 8 \times 8$  in index form.

Answer: .....  
\_\_\_\_\_

3. Simplify  $3c + 8c$

Answer: .....  
\_\_\_\_\_

4. Work out  $14 + 6 \div 2$

Answer: .....  
\_\_\_\_\_

5. Complete the Fibonacci sequence below.

1, 3, 4, 7, .....

\_\_\_\_\_

6. Find the number which is exactly halfway between 8 and 8.4

Answer: .....  
\_\_\_\_\_

7. Reduce the fraction  $\frac{18}{50}$  in its lowest term.

Answer: .....

---

8. State the mode of the set of numbers below

40, 40, 41, 45, 43, 42, 42, 38, 42

Answer: .....

---

9. Calculate 10% of 850

Answer: .....

---

10. Salman buys a T.V set for Rs. 40 000. After 2 years, he sold the T.V set for Rs. 30 000.  
Calculate the loss that he made.

Answer: .....

---

11.  $\sqrt{2}, \pi, \sqrt{7}, \sqrt{5}$

The numbers listed above are known as .....

- A rational numbers
  - B irrational numbers
  - C prime numbers
  - D integers
-



12. The 10<sup>th</sup> of September is a Tuesday. Which day will it be on the 20<sup>th</sup> of September of the same year?

- A Tuesday
  - B Wednesday
  - C Thursday
  - D Friday
- 

13. The temperature on one Sunday morning in Australia was 40°C. In the afternoon, the temperature had gone down by 20°C. What was the temperature in the afternoon?

- A 80 °C
  - B 60 °C
  - C 20 °C
  - D -20 °C
- 

14. The expansion of  $(a + b)^2$  is .....

- A  $a^2 + b^2$ .
  - B  $a^2 - b^2$ .
  - C  $a^2 + ab + b^2$ .
  - D  $a^2 + 2ab + b^2$ .
- 

15. The formula for the area of a circle is .....

- A  $2\pi r$
  - B  $\pi r^2$
  - C  $2\pi r^2$
  - D  $\pi r^2 h$
- 

16.

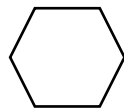

The above polygon is known as .....

- A a pentagon
  - B a hexagon
  - C an octagon
  - D a nonagon
-

17. The solution of the equation  $2x + 1 = 9$  is \_\_\_\_\_.

- A  $x = 6$
  - B  $x = 5$
  - C  $x = 4$
  - D  $x = 3$
- 

18. Which of the following is a quadratic equation?

- A  $2x + 5 = 0$
  - B  $x^2 - 2x - 3 = 0$
  - C  $x^2 + 5x$
  - D  $\frac{3}{x^2} + 2x + 9$
- 

19. The probability that it will rain tomorrow is  $\frac{2}{7}$ . What is the probability that it will **not** rain tomorrow?

- A  $\frac{2}{7}$
  - B  $\frac{3}{7}$
  - C  $\frac{4}{7}$
  - D  $\frac{5}{7}$
- 

20. The shape below is known as a .....

- A prism
- B triangle
- C cuboid
- D cylinder

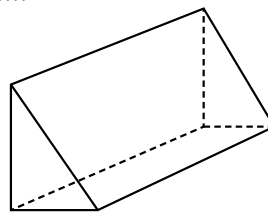

21. From the list of numbers below, ring the integers.

1.1 ,  $\frac{3}{4}$  , -5 ,  $\frac{9}{7}$  ,  $1\frac{2}{5}$  , 2

---

22. Work out

$$\begin{pmatrix} 3 \\ 2 \\ 5 \end{pmatrix} + \begin{pmatrix} 1 \\ 0 \\ 4 \end{pmatrix}$$

Answer: .....

---

23. Simran shared an amount of money equally among her three children. Each child received Rs. 50. What is the amount of money that Simran had before sharing?

Answer: .....

---

24. Find the angle  $x$  in the diagram below.

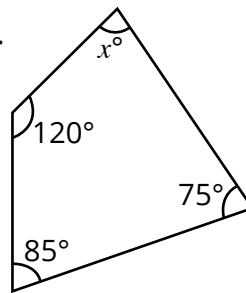

Answer: .....  $x^\circ =$  .....

---

25. What is the name of the polygon below?

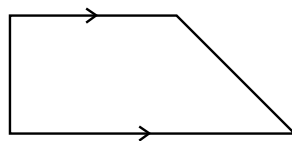

Answer: .....

---

26. Simplify  $\left(\frac{a}{b^2}\right)^3$

Answer: .....

---

27. Simplify  $\frac{4xy}{2y}$

Answer: .....

---

28. Solve the inequality  $3x \leq 18$ .

Answer: .....

---

29. Simplify  $y(y + 2)$ .

Answer: .....

---

30. Given that  $y + 3x = 6$ , make  $y$  the subject of formula.

Answer: .....

---

31. An amount of Rs.15 000 is to be repaid in 5 equal monthly instalments. Calculate the amount for one monthly instalment.

Answer: .....

---

32. In a book with 200 printed pages, Ken has read 165 pages. How many pages are left for him to read the book completely?

Answer: .....

---

33. Draw the line(s) of symmetry of the equilateral triangle given below.

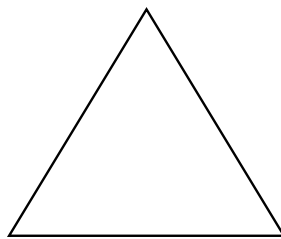

34. State the coordinates of the point of intersection of the two lines below.

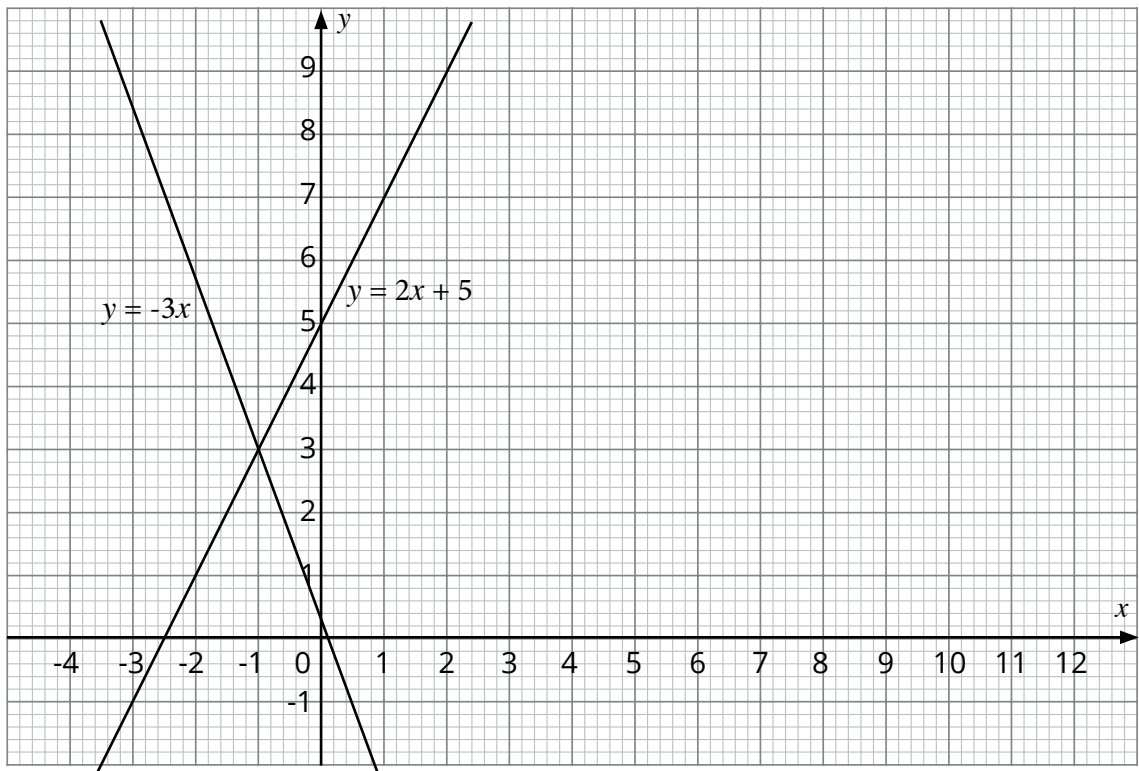

Answer: .....

---

35. Represent the vector  $\vec{PQ} = \begin{pmatrix} 3 \\ 2 \end{pmatrix}$  on the grid below.

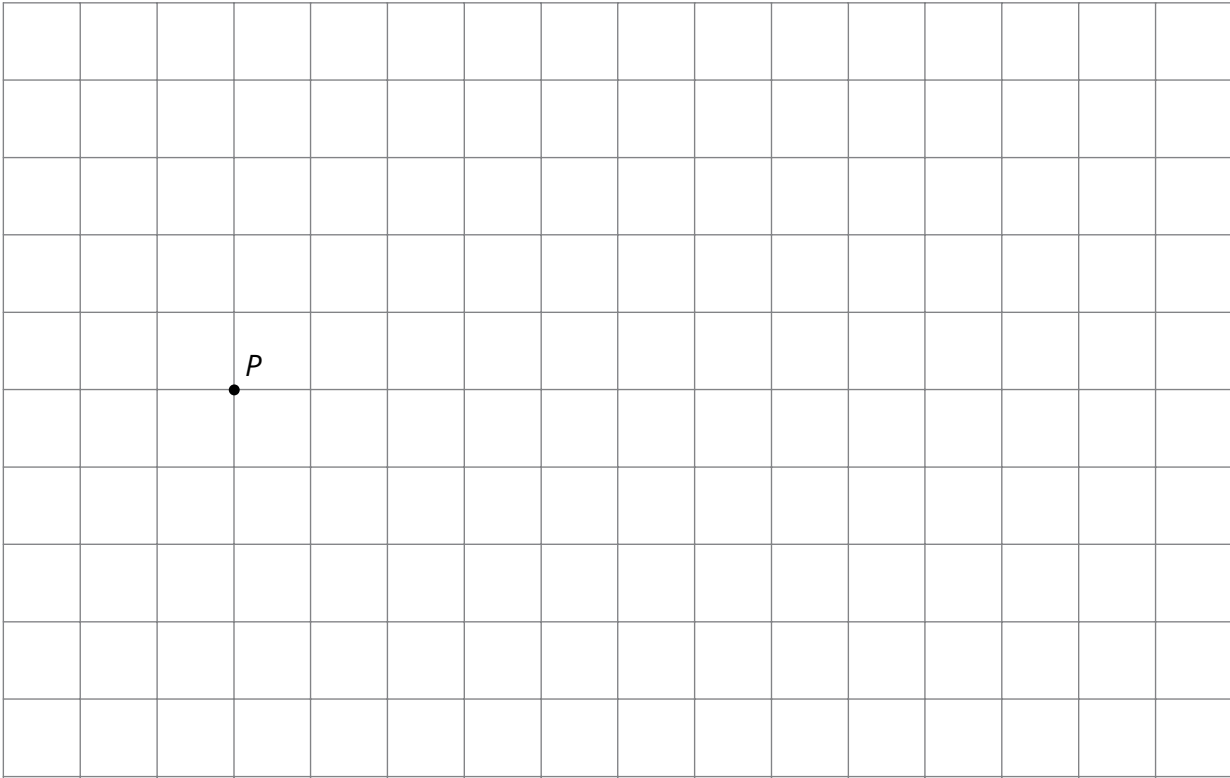

---

36. Find the mean of the numbers 10, 25 and 25.

Answer: .....

---

37. Use the formula  $a^2 - b^2 = (a + b)(a - b)$  to find the value of  $37^2 - 13^2$ . (You should not use long multiplication)

Answer: .....

---

38. Find the angle  $x$ .

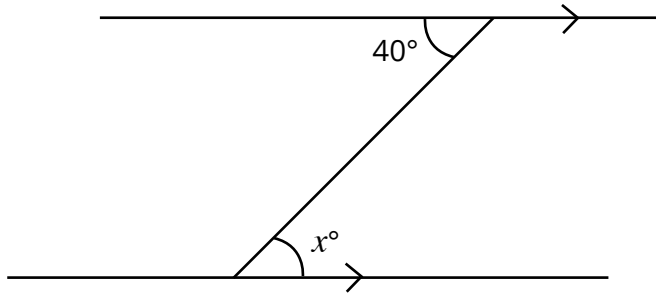

Answer: .....  $x^\circ =$  .....

39. Given that  $A = \{p, q, r\}$  and  $B = \{r, s\}$ , list the elements of  $A \cup B$ .

Answer: .....

40. The length of the rectangle below is **twice** the width. Calculate the perimeter of the rectangle.

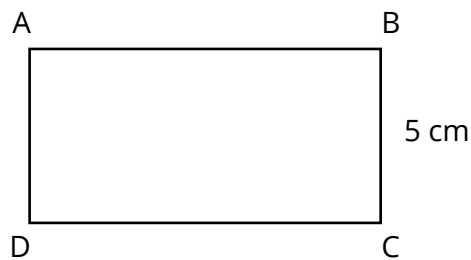

Answer: .....





# GRADE 9+

## Extended Programme

---

**MATHEMATICS**

**Practice Paper 9**  
**1 Hour**

---

**Read these instructions first**

- Write your name in the space provided below.
- Use black or blue ink.
- HB pencils may be used for the diagrams / sketches only.
- Do not use correction fluid.
- Read each question carefully.
- All answers must be written in the spaces provided.
- Answer all questions.
- Any rough working should be done in this booklet.
- Each question carries 1 mark.
- The total number of marks for this paper is 40 marks.

**Name of student :** .....



1. Work out

$$\begin{array}{r} 758 \\ - 215 \\ \hline \\ \hline \end{array}$$

---

2. Write in figures: **Two thousand one hundred and sixty.**

Answer: .....

---

3. Evaluate  $6 + 12 \times 3$ .

Answer: .....

---

4. Calculate the value of  $1.2 \times 4$

Answer: .....

---

5. Work out.

$$\frac{5}{11} - \frac{1}{11}$$

Answer: .....

---

6. Express  $\frac{87}{100}$  as a decimal.

Answer: .....

---

7. Simplify the ratio 8 : 24 in its lowest term.

Answer: .....

---

8. From the list below, ring the square number.

14       $\sqrt{5}$       16       $\pi$

---

9. Find the L.C.M. of 6 and 8.

Answer: .....

---

10. Simplify  $2 \times 3y$

Answer: .....

---

**Circle the letter corresponding to the correct answer in each of the following items from questions 11 to 20.**

11. A decagon has ..... sides.

- A 7
  - B 8
  - C 9
  - D 10
- 

12. Which of the following are **like** terms?

- A  $3ab$  and  $2a$
  - B  $3ab$  and  $2x$
  - C  $3a$  and  $2a$
  - D  $3ab$  and  $2$
- 

13. The figure 10.156 correct to 2 decimal places is .....

- A 10
  - B 10.1
  - C 10.15
  - D 10.16
-

14. The value of  $3^{-1}$  is .....

- A -3
  - B  $-\frac{1}{3}$
  - C  $\frac{1}{3}$
  - D 2
- 

15. The matrix  $\begin{pmatrix} 2 & 3 \\ 1 & 6 \\ 5 & 1 \end{pmatrix}$  has ..... rows.

- A 2
  - B 3
  - C 4
  - D 6
- 

16. The solution of the equation  $\frac{2x}{5} = 4$  is .....

- A 4.5
  - B 10
  - C 20
  - D 40
- 

17. The shaded region in the Venn diagram below represents .....

- A  $P \cup Q$
- B  $P \cap Q$
- C  $P^c$
- D  $Q^c$

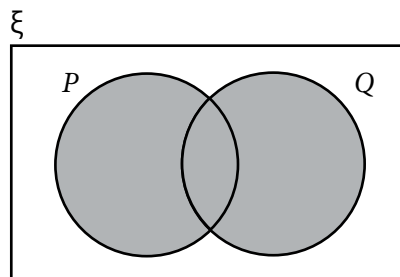

18. Which of the following diagrams represents a line XY with a positive gradient?

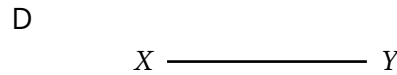
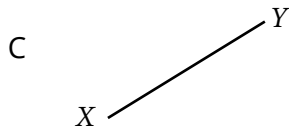
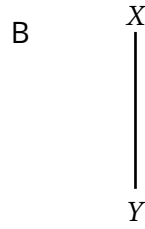
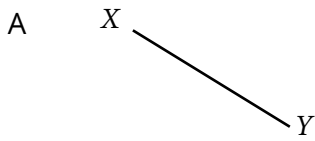

---

19. Taking  $\pi$  to be  $\frac{22}{7}$ , the circumference of the circle below is given by .....

A  $2 \times \frac{22}{7} \times 14$

B  $2 \times \frac{22}{7} \times 7$

C  $\frac{22}{7} \times 14^2$

D  $\frac{22}{7} \times 7^2$

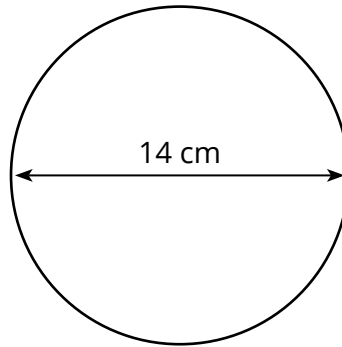

---

20. The perimeter of the rectangle below is 40 cm.

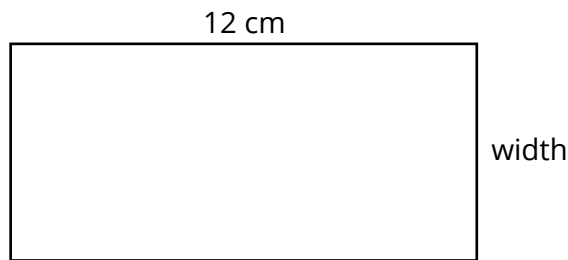

Given that the length is 12 cm, find the width of the rectangle.

- A 8 cm
- B 10 cm
- C 12 cm
- D 20 cm

21. Fill in the blank with < or >.

$$2\frac{1}{2} \quad \text{——} \quad 2\frac{1}{8}$$

---

22. Convert 7.2 litres into millilitres.

Answer: .....

---

23. Express 500 m as a fraction of 2 km.

Answer: .....

---

24. The pie chart below shows the fruit preferences of students in a class. Which fruit did they like the most?

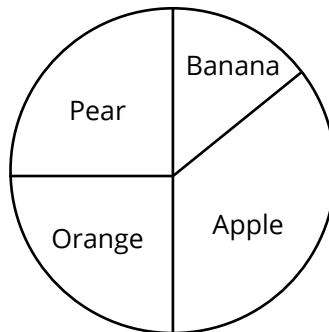

Answer: .....

---

25. Given that  $b = 3a + c$ , find the value  $b$  of if  $a = 10$  and  $c = -2$ .

Answer: .....

---

26. The graph shows the line  $y = x$ . State the coordinates of two points on the line.

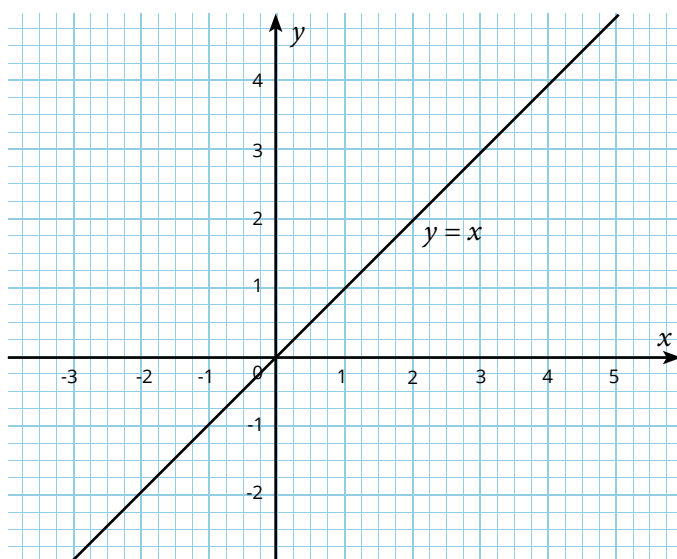

Answer: .....

---

27. Match the following.

Cylinder

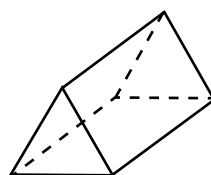

Triangular prism

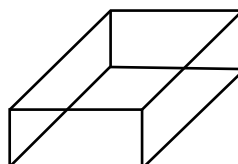

Cuboid

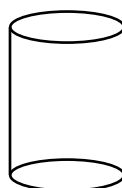

---

28. Write the next term in the sequence below.

$$1 \times 1 + 1$$

$$2 \times 2 + 3$$

$$3 \times 3 + 5$$

\_\_\_\_\_

---



29. Given that  $\vec{PQ} = \begin{pmatrix} 2 \\ -1 \end{pmatrix}$ , write down  $\vec{QP}$ .

Answer: .....

---

30. Complete the diagram given that the dotted line is the line of symmetry.

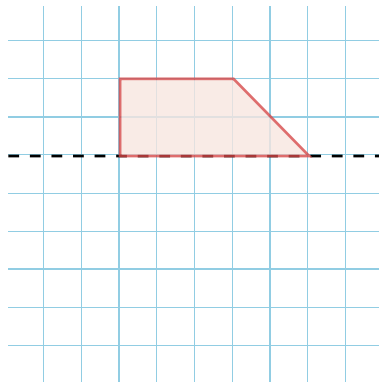

---

31. Julia shared a sum of Rs 240 equally among her 4 children.  
How much did each child get?

Answer: .....

---

32. Find the value of  $y$  in the triangle below.

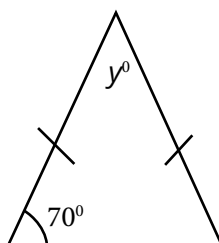

Answer: .....  $y =$  .....

---

33. Work out.

$$3\begin{pmatrix} 5 \\ 2 \end{pmatrix} - \begin{pmatrix} 1 \\ 0 \end{pmatrix}$$

Answer: .....

---

34. Expand  $x(x - 3)$ .

Answer: .....

---

35. Find the value of  $x$  in the diagram below.

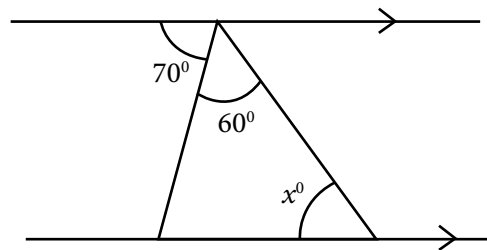

Answer: .....

---

36. Find the **median** of the set of numbers.

10, 12, 14, 17, 20

Answer: .....

---

37. Rishi bought an article at Rs 500. He made a loss of Rs 200 when he sold it.  
At what price did he sell the article?

Answer: .....

---

38. Solve the inequality  $3x + 1 < 7$

Answer: .....  
\_\_\_\_\_

39. Given that  $4x + y = P$ , make  $x$  the subject of formula.

Answer: .....  
\_\_\_\_\_

40. Find the probability that the spinner lands on 3 when it is spun.

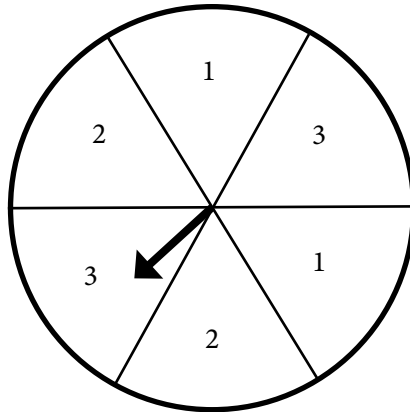

Answer: .....  
\_\_\_\_\_



# GRADE 9+

## Extended Programme

---

**MATHEMATICS**

**Practice Paper 10**  
**1 Hour**

---

**Read these instructions first**

- Write your name in the space provided below.
- Use black or blue ink.
- HB pencils may be used for the diagrams / sketches only.
- Do not use correction fluid.
- Read each question carefully.
- All answers must be written in the spaces provided.
- Answer all questions.
- Any rough working should be done in this booklet.
- Each question carries 1 mark.
- The total number of marks for this paper is 40 marks.

**Name of student :** .....



1. Write 304 in words.

Answer: .....

---

2. Work out.

$$123 \times 3$$

Answer: .....

---

3. Express  $\frac{3}{10}$  as a decimal.

Answer: .....

---

4. Find the value of  $3^2 + 1$ .

Answer: .....

---

5. Complete the sequence

2.2, 2.4, 2.6, .....

---

6. Calculate 10 % of Rs 700.

Answer: .....

---

7. Express 5 months as a fraction of one year.

Answer: .....

---

8. Work out.

$$(6 \times 100) \div (3 \times 50)$$

Answer: .....

---

9. Solve the equation  $\frac{y}{5} = 2$ .

Answer: .....

---

10. Simplify  $2p \times 3$

Answer: .....

---

**Circle the letter corresponding to the correct answer in each of the following items from questions 11 to 20.**

11. The value on the number line represents

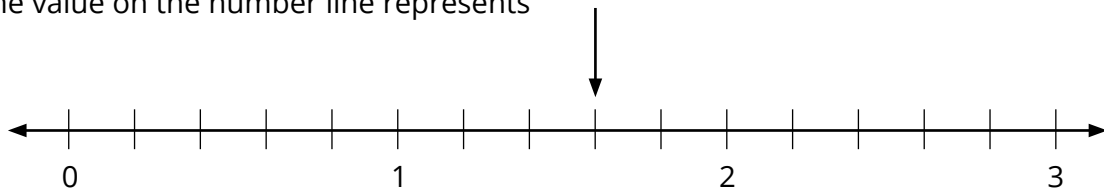

- A 1.3
  - B 1.5
  - C 1.6
  - D 1.8
- 

12. The sum of angles in a quadrilateral is equal to .....

- A  $90^\circ$
  - B  $180^\circ$
  - C  $270^\circ$
  - D  $360^\circ$
-



13. One bottle contains 1.5 litres of water. 6 identical bottles contain ..... litres of water.

- A 9.0
  - B 7.5
  - C 6.0
  - D 4.5
- 

14. Raj buys a mobile phone at Rs 13000. After 5 months, he sold the phone for Rs. 9500. Which of the following statement is correct?

- A Raj made a profit of Rs. 3500.
  - B Raj made a loss of Rs. 3500.
  - C Raj made a profit of Rs. 4500.
  - D Raj made a loss of Rs. 4500.
- 

15. A circle is divided into 6 equal sectors. One such sector is shown below.

The value of  $x$  is .....

- A  $30^\circ$
- B  $45^\circ$
- C  $60^\circ$
- D  $90^\circ$

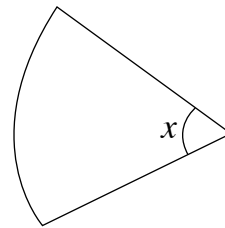

16.

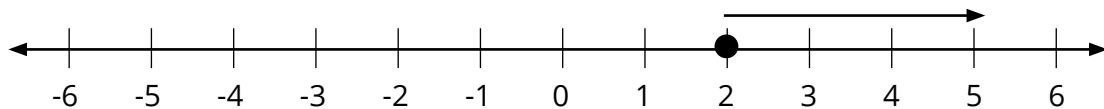

The set of values represented by the arrow on the number line above is given by a

- A  $x > 2$
  - B  $x < 2$
  - C  $x \geq 2$
  - D  $x \leq 2$
-

17. Which trigonometric ratio below is correct?

A  $\sin\theta = \frac{\text{opposite}}{\text{adjacent}}$

B  $\cos\theta = \frac{\text{opposite}}{\text{adjacent}}$

C  $\tan\theta = \frac{\text{opposite}}{\text{adjacent}}$

D  $\sin\theta = \frac{\text{opposite}}{\text{adjacent}}$

---

18. The gradient of line AB is

- A positive
- B negative
- C zero
- D undefined

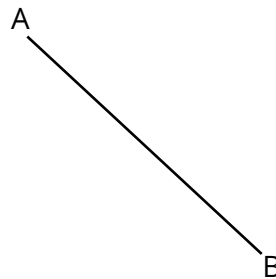

19. The formula  $C = 2\pi r$  is used to find .....

- A the area of a circle
  - B the circumference of a circle
  - C the area of a sector
  - D the length of arc
- 

20. (1, 2) is a solution of which of the following simultaneous equations ?

- A  $y = x + 1$  and  $y = 2x - 1$
  - B  $y = x + 1$  and  $y = x + 2$
  - C  $y = 2x$  and  $y = x + 1$
  - D  $y = 2x$  and  $y = 2x - 1$
-

21. Find the H.C. F. of 10, 15 and 20.

Answer: .....

---

22. A car covers a distance of 180 km in 3 hours. What is the speed of the car in km/h?

Answer: .....

---

23. Simplify  $x^{12} \div x^4$

Answer: .....

---

24. The following table represents the times taken by four friends to run a 100-metre race.

<b>Name</b>	<b>Time taken in seconds</b>
Rajesh	10.04
Dany	10.12
Shafeeq	10.44
David	10.01

Who came first in the race?

Answer: .....

---

25. Find the gradient of the line with equation  $3y = -3x + 6$ .

Answer: .....

---

26. It is given that  $v = u + 10t$ . Find the value of  $v$  when  $u = 3$  and  $t = 5$ .

Answer: .....

---

27. Factorise the expression  $x^2 - 4$

Answer: .....

---

28. Expand  $2(m - 7)$

Answer: .....

---

29. Find the value of  $\sqrt{\frac{9}{16}}$ .

Answer: .....

---

30. Calculate the value of the angle  $p$ .

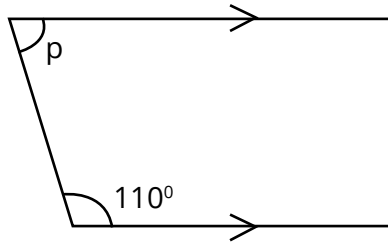

Answer: .....

---

31. Find the size of one exterior angle of a regular pentagon.

Answer: .....

---

32. In the diagram below, AB is the line of symmetry. Complete the diagram.

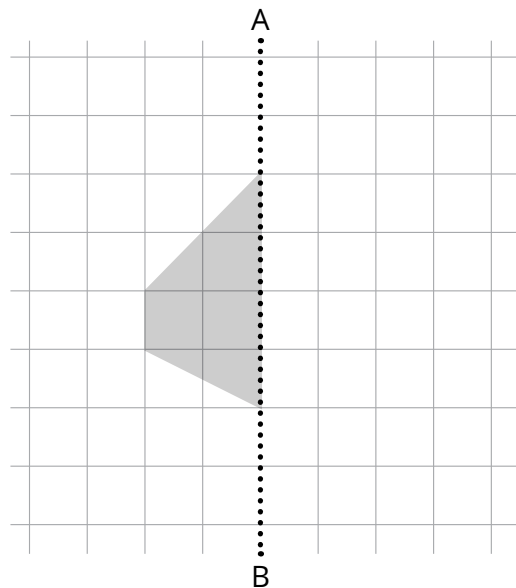

---

33. Calculate the area of the triangle below.

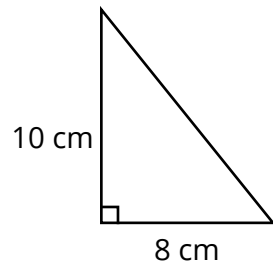

Answer: .....

---

34. Find the **median** of the following set of numbers:

12, 14, 15, 12, 10, 11

Answer: .....

---

35. Work out

$$\begin{pmatrix} 1 & 3 \\ 2 & 4 \end{pmatrix} - \begin{pmatrix} 1 & 2 \\ 3 & 2 \end{pmatrix}$$

Answer: .....

---

36. Write down the column vector representing  $\vec{AB}$ .

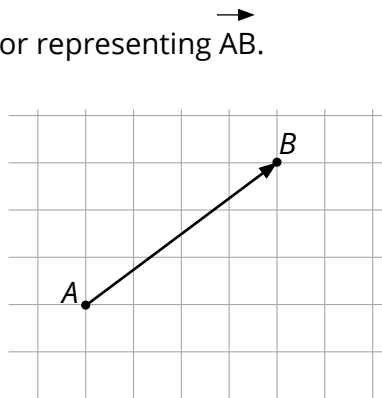

Answer: .....

---

37. The diagram below shows the size of shirts worn by a group of persons during a survey.

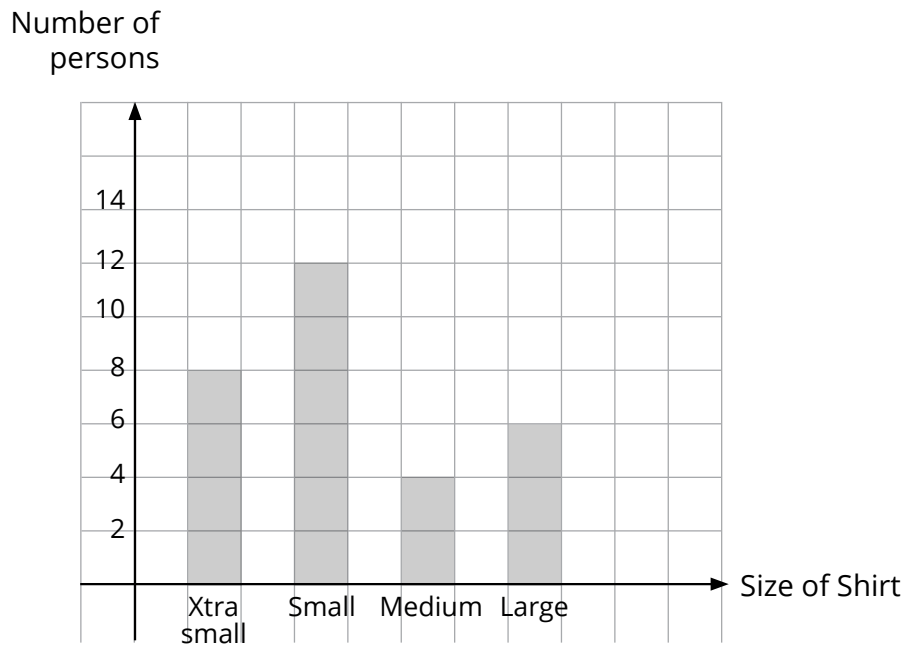

How many persons were there **in all** in the survey?

Answer: .....

---

38. A fair die is thrown. Find the probability of obtaining a number greater than 5.

Answer: .....

---

39. Given that  $a^2 + b^2 = 58$  and  $ab = 21$ , find the value of  $(a+b)^2$ .

Answer: .....

---

40. The area of the cross section ABC of the prism is  $100 \text{ cm}^2$ . Given that the depth of the prism is 30 cm, calculate the volume of the prism.

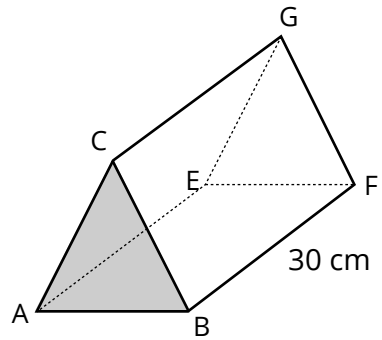

Answer: .....

---